

Instructions for Use

Pulley
P1 & P1D PMP
Ball Bearing

Manufactured in **USA** using domestic & foreign materials

WARNING! 

For expert use only!

• These activities are inherently dangerous and carry a significant risk of injury or death that cannot be eliminated.

• It is the user's responsibility to obtain specific training and to use it safely. These instructions DO NOT tell you everything you need to know.

• Do not use unless you can and will understand and assume all risks and responsibilities for all damage/injury/death that may result from use of this equipment or the activities undertaken with it.

• Any device is subject to failure-carefully check before and after each use.

• You must always have a backup-never trust a life to a single tool.

• Everyone using this equipment must be given and thoroughly understand the instructions and refer to them before each use.

• You must have a rescue plan and the means to implement it. Inert suspension in a harness can quickly result in death!

• Do not use around electrical hazards, moving machinery or near sharp edges or abrasive surfaces.

• We are not responsible for any direct, indirect or accidental consequences or damage resulting from the use of our products.

rockexotica.com

rock exotica equipment LC
POB 160470
Freeport Center, F-11
Clearfield, UT 84016
USA
801 728-0630

INTRODUCTION

Thank you for purchasing this Rock Exotica product. The sheaves of these pulleys are equipped with ball bearings for efficiency. The axle heads are low-profile to help avoid hanging up on other gear.

History: These pulleys are evolutions of our original Prusik Minding Pulleys which were the first of their kind and emerged during the religious wars between the proponents of mechanical cams and the anti-cam Prusik legions. They have become a world-wide standard and many manufacturers have copied them.

Strength: In a single pulley, half the load is on one side of the rope and half is on the other. The total load on the pulley is thus 2x the mass that is being raised or lowered. In a double pulley the total load is 4x the load on the 4 individual ropes. This is illustrated on the pulley. Breaking Strength & Working Load are based on this equal loading.

Sideplates must be closed and all plates must be attached to the anchor. Connecting to only one sideplate is absolutely forbidden!

Pulleys must be free to align with the load, **any restraint is dangerous.**

Working Load Limit: Is based on about a 6:1 safety factor. You must decide if that is sufficient in your situation or if you need to adjust the WLL.

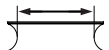
	P1 Single P1D Double
	2.0" (51mm)
Max Rope	13mm
Strength	36kN Single 44kN Double*
WLL	6kN Single 8kN Double
Height**	4.9" (125mm) S 6.4" (163mm) D
Width	3.8" (96mm) S 4.2" (108mm) D
Weight	9.9 oz (280gm) S 20 oz (575gm) D

* The Double achieves full strength when equally loaded over both sheaves.

** The double pulley is longer because of the becket

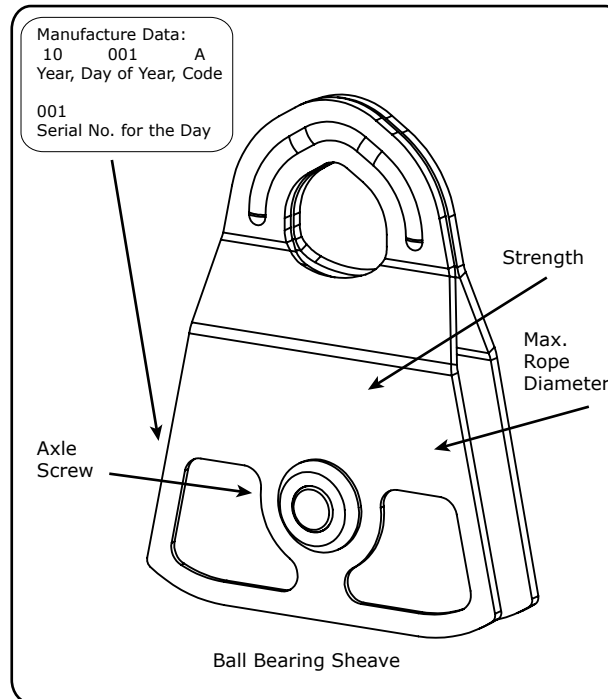
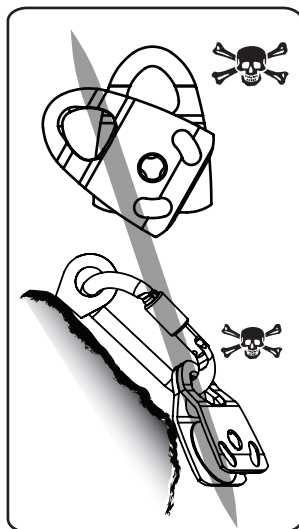
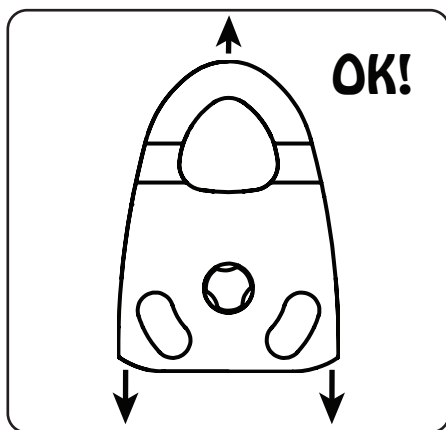

Prusik Use - Caution!

Prusiks must always have an experienced person tending them. Never allow a jammed Prusik to be pulled in between the sideplates. This can bend or break the pulley and allow the rope to fall out.

Breakage Hazard

Do not let an object in between the sideplates and never rig your system so that the pulley is forced against something that could break the sideplates or your connector.

Leverage Hazard

A pulley or other equipment can lever against a connector (such as a carabiner) and break it, opening the connector and allowing the pulley to fall out. Guard against this at all times!

Pinching Hazard

Rope travelling through a pulley can suck in hair, fingers, clothing, etc., causing injury & jamming the pulley. Guard against this.

Inspect Before & After Use

Check all parts for cracks, deformation, corrosion, wear, etc. Verify that the sideplates rotate normally & the axle screw is has not loosened. Verify smooth rotation of the sheave.

Inspection During Use

Regularly inspect and monitor your system, confirming proper connections, equipment position, fully locked connectors, etc.

Stay Up To Date!

Regularly go to our website and read the latest user instructions.

Intended Use

This Personal Protective Equipment (PPE) should only be used with energy absorbing systems such as dynamic ropes, energy absorbers, etc. & slack must be kept out of the system to prevent high impact falls. It is intended for use by medically fit, specifically trained and experienced users.

Thorough and specific training is absolutely essential before use.

Being at height is dangerous and it is up to you to reduce the risks as much as possible - but the risks can never be eliminated. There are many ways to misuse this equipment, too many to list or imagine. You must personally understand and assume all risks and responsibilities of using this equipment. If you cannot or do not want to do this, do not use this equipment.

Environmental Factors

Moisture, ice, salt, sand, snow, chemicals and other factors can prevent proper operation or can greatly accelerate wear.

PURCHASE RECORD	
Model	
Complete Batch #	
Year of Manufacture	
Purchase Date	
Date of 1st Use	
User	

Special Rigging for Mechanical Advantage Systems

The low axles and slightly more compact size of the single pulleys allow a carabiner to act as a becket for attaching a rope or another pulley. This lets you build the system you need from individual pulleys for emergency or special uses.

Note: Not all carabiners will fit well. Determine compatibility and practice in a controlled situation. All components must keep proper position at all times. **Special rigging skills and experience are required.**



Single pulley with becket



Double Pulley



Triple Pulley

Advanced Users Only!

Compatibility

Verify compatibility with other components of your system. Incompatible connections can cause detachment, breakage, etc.

Lifetime

10 years maximum, but will often be much less depending on conditions and use; it could even be a single use in some cases.

Retire from Service & Destroy if it:

1. Is significantly loaded.
2. Does not pass inspection or there is any doubt about its safety.
3. Is misused, altered, damaged, exposed to harmful chemicals, etc.
4. Sheave does not rotate smoothly. Consult the manufacturer if you have any doubts or concerns.

Maintenance & Storage

Clean if necessary with fresh water, then allow to dry completely. Store in a dry place away from extremes of heat and cold and avoid chemical exposure.

Principal Material

Aluminum alloy, anodized.

Repairs or Modifications to Equipment

Are only allowed by the manufacturer or those authorized in writing by the manufacturer.

Detailed Inspection

In addition to inspection before, during and after each use, a detailed inspection by a competent inspector must be done at least every 3 months or more frequently depending on amount and type of use. Make a copy of these instructions and use one as the permanent inspection record and keep the other with the equipment.

It is best to issue new gear to each user so they know its entire history.

DATE	CONDITION	INSPECTOR